



**FAMILY, CAREER AND COMMUNITY LEADERS OF AMERICA**  
*AT THE GEORGIA NATIONAL FAIR*

Family, Career and Community Leaders of America is a national student organization which functions as an integral part of the Family and Consumer Sciences curriculum in Georgia schools. FCCLA encourages personal growth, prepares for careers, fosters family and community involvement and helps students become leaders. Through programs such as Career Connection and Leaders At Work, students prepare for the world of work. Programs such as Families First and Families Acting for Community Traffic Safety reinforce the importance of a strong home life. The Community Service Award, STOP the Violence program and the Japanese Exchange Program provide incentives to developing local, national, even global, community ties. The Power Of One, Student Body and Financial Fitness program encourage members to make positive lifestyle choices and practice goal setting. Leadership skills are enhanced through opportunities to serve as local, state and national officers. Conferences such as state and national leadership meetings and regional cluster meetings provide intense leadership training and the chance to network with teens who have similar interests and concerns. Through the STAR Events program, members are recognized for proficiency and achievement in leadership and career skills. FCCLA is The Ultimate Leadership Experience!

The mission of FCCLA is to promote personal growth and leadership development through Family and Consumer Sciences education. Focusing on the multiple roles of family member, wage earner and community leader, members develop skills for life through character development, creative and critical thinking, interpersonal communication, practical knowledge and career preparation.

Open to all bona fide FCCLA members in the state of Georgia. Entries may be made as individuals or teams, as specified in the rules for each competition and must be submitted through the club advisor.



[www.GeorgiaNationalFair.com](http://www.GeorgiaNationalFair.com)

**Chapters must have submitted an affiliation form for the current school year to the state and national offices to be eligible to participate. Each participating member must be listed on the affiliation form. Affiliation forms are available on the state website at:**

**[www.gafccla.com](http://www.gafccla.com)**

## FCCLA SCHEDULE OF EVENTS

**Deadline for entry registration - Wednesday, Sept. 20.**

### **Wed. Sept. 27 - Sat., Sept. 30**

Chapter Booth Setup (MMH Bldg.)

Weekdays 9:00 a.m. - 5:00 p.m.

Saturday 10:00 a.m. - 3:00 p.m.

### **Tue., Oct. 10**

**1:00 P.M.** Chili Cook-off Middle School  
Miller-Murphy-Howard Building, North End of Building

**3:00 P.M.** Chili Cook-off High School  
Miller-Murphy-Howard Building, North End of Building

### **Wed., Oct. 11**

**9:45 A.M.** Middle School Georgia Peanut Recipe Contest  
Junior (Grades 9 - 10) Georgia Peanut Recipe Contest  
Senior (Grades 11 - 12) Georgia Peanut Recipe Contest  
Miller-Murphy-Howard Building Culinary Area (East Side of Building)

**1:15 P.M.** Culinary Competition  
Miller-Murphy-Howard Building, North End of Building

**2:00 P.M.** Knowledge Bowl Finals  
Miller-Murphy-Howard Building, West Conference Rooms

**Tues., Oct. 17, 12:00 P.M. - Release of entries begins**  
**There will be no early release of entries.**

**ALL EXHIBITORS ARE REQUIRED TO READ AND ABIDE BY THE GEORGIA NATIONAL FAIR GENERAL RULES AND REGULATIONS. PLEASE NOTE: IT IS YOUR RESPONSIBILITY TO READ AND UNDERSTAND THE RULES. IF YOU HAVE QUESTIONS, YOU MAY CERTAINLY EMAIL US AT CONTESTS@GNFA.COM. PLEASE HELP US PREVENT ENTRY DISQUALIFICATIONS.**

Advisors should call 800-987-3247, ext. 555 or email [contests@gnfa.com](mailto:contests@gnfa.com) to obtain required password, which must be obtained by Sept. 18, 2017. Enter online at <http://www.georgianationalfair.com/youth-educational-exhibits/> by September 20, 2017. **No substitutions allowed. Late entries will not be processed.**

Exhibitors will be required to turn in a copy of their online registration confirmation to check-in for competitions.

Chapters must have submitted and paid affiliation through the FCCLA system to be eligible to participate. Find affiliation information online at:  
[www.gafccla.com](http://www.gafccla.com)

## **GEORGIA NATIONAL FAIR FCCLA SUPERIOR CHAPTER AWARD**

**1<sup>st</sup> Place - Superior Chapter - \$500**  
**2<sup>nd</sup> Place - Reserve Superior Chapter - \$250**

Sponsored by the Georgia National Fair

All placings will be put on a point system: 1st place=20 pts., 2nd place=15 pts., 3rd place=10 pts., 4th place=5 pts. These points will be calculated by chapter and the chapter with the highest accumulated points after the last competition will receive a GNF Superior Chapter Award plaque and \$500. The second place chapter will receive a GNF Reserve Superior Chapter Award plaque and \$250.

# FCCLA CHAPTER BOOTH

**THIS IS A CHAPTER EVENT AND SHOULD BE ENTERED IN THE CLUB NAME (EXAMPLE: Smith High School FCCLA).**

Enter online at [www.GeorgiaNationalFair.com](http://www.GeorgiaNationalFair.com)  
 (<http://www.georgianationalfair.com/youth-educational-exhibits/>) by **September 20, 2017.**

**Chapter Booth Setup:** September 27 - 30; weekdays 9 a.m. - 5 p.m., Saturday, 10 a.m. - 3 p.m. THE MILLER-MURPHY-HOWARD BUILDING. **Please allow ample time for set-up. The Building will close at 5 p.m. on weekdays and 3 p.m. on Saturday. You will not be able to stay past closing time, nor will you be allowed access to the building before 9 a.m.**

**\*\*\*NO SUNDAY DELIVERY\*\*\***

The educational exhibits of the Georgia National Fair are designed to promote better understanding of the focus of Family and Consumer Sciences and the mission of the Georgia Association of Family, Career and Community Leaders of America.

**DIVISION 20103      FCCLA CHAPTER BOOTH MIDDLE SCHOOL**  
**DIVISION 20104      FCCLA CHAPTER BOOTH HIGH SCHOOL (GRADES 9-12)**  
**CLASS**  
**01 Chapter Booth**

|                   |   |
|-------------------|---|
| First Place.....  | \$125 Publix Bonus Award; GNF \$375 & Rosette |
| Second Place..... | \$125 Publix Bonus Award; GNF \$325 & Rosette |
| Third Place.....  | \$125 Publix Bonus Award; GNF \$275 & Rosette |
| Fourth Place..... | \$125 Publix Bonus Award; GNF \$225 & Rosette |

View the 1st thru 4th place Chapter Booth entries at <http://www.gafccla.com/photos1.htm>.

**A copy of the online registration confirmation will be required to check-in for competition.**

**This is a chapter event and should be entered in the club name (ex. Smith High School FCCLA).**

**CONTEST RULES:**

1. **ALL EXHIBITORS ARE REQUIRED TO READ AND ABIDE BY THE GEORGIA NATIONAL FAIR GENERAL RULES AND REGULATIONS. PLEASE NOTE: IT IS YOUR RESPONSIBILITY TO READ AND UNDERSTAND THE RULES. IF YOU HAVE QUESTIONS, YOU MAY CERTAINLY EMAIL US AT CONTESTS@GNFA.COM. PLEASE HELP US PREVENT ENTRY DISQUALIFICATIONS.**
2. All Georgia affiliated FCCLA chapters are eligible to participate. **Please see box at the bottom of page 1 for additional instructions.**
3. A chapter may enter only one exhibit.
4. Application for exhibit space should be submitted by chapters registering online at <http://www.georgianational-fair.com/youth-educational-exhibits/> by **September 20, 2017.**
5. Exhibits should be based on current FCCLA state or national programs or areas of skill development. The exhibit should be informative and well organized. Animation is encouraged to promote dramatization. Projects should be developed into an exhibit to accommodate a triangular space 4'x4'x5'6", with a two-sided backdrop of 4'x8' plywood panels hinged together, so that decorations of your choice may be stapled or thumb tacked to them. (Do not use glue or paint.) No alterations or cutting of booths will be permitted. Height of the exhibit should not exceed the height of the booth. These panels will be supplied by the Fair and will be in place ready for use by September 30. Use of the floor space within the triangle to create a three-dimensional exhibit is strongly encouraged. **The 12"x5'6" title board must be displayed across the top.** See sketch on next page. You are encouraged to pre-make displays designed to slide into the booth, but keep in

mind that they may not extend outside of the stated measurements. We recommend that any pre-made elements be made slightly smaller than approximate measurements of booth. Any spaces can be filled with borders, etc.

6. **Please bring no more than five students to set up exhibit.**
7. All electrical or mechanical equipment included in the exhibit to create motion or action should be so well constructed that it will operate for the duration of the Fair. Electricity will be available; please be sure to indicate on your space application if you need booth electricity. (Electricity for glue gun, stapler, etc. will be provided.)
8. Title sign should state the theme of the exhibit, and all things used in the exhibit should contribute to the theme.
9. Signs announcing the name of the chapter must be covered until after the exhibits are judged.
10. **There will be a 2 point deduction for not following the guidelines.**
11. **Chapters entering must assume all responsibility for placing and removing their exhibits.** All display apparatus such as placards, models and other articles are to be provided by the exhibitor.
12. **Miller-Murphy-Howard Building will be open: September 27 - 30, Weekdays, 9 A.M. - 5 P.M., Saturday 10 A.M. - 3 P.M., for the arrangement of exhibits. There will be no set-up outside of these hours. \*\*\*NO SUNDAY DELIVERY\*\*\* CLUBS WILL BE ALLOWED TO SET UP ON ONE DAY ONLY; RETURN TRIPS TO MODIFY/COMPLETE DISPLAYS WILL NOT BE ALLOWED.** Exhibits must be in place, ready to be judged by 3 P.M., September 30.
13. **There will be no Sunday evening exhibit release.** Exhibits must be removed Tuesday, October 17 between 12 P.M. and 8 P.M., Wednesday, October 18 between 10 A.M. and 4 P.M. or Saturday, October 21 between 10 A.M. and 3 P.M. **All exhibits left after Saturday, October 21, 3 P.M. deadline will be discarded.** If for some reason you are unable to return to dismantle your display, please make arrangements with another advisor/volunteer to do so or notify GNF staff.
14. **CANCELLATIONS:** Please!! If you see that your chapter will not use the space you have reserved by preregistration, call the Fair (800-987-3247 ext. 553) and leave a message for the FCCLA coordinator. Large exhibit spaces are difficult to deal with when left empty at Fair time. Thanks for your cooperation.
15. We appreciate your help in telling your story to the Fair visitor in an effective and dramatic way. Judges will be asked to award \$50.00 and a Georgia National Fair Rosette to those exhibits of merit that do not place in the top 5 exhibits in each category, **provided the exhibits are properly removed.** All staples/tacks, etc. should be removed from the display.

### Chapter Booth Dimensions

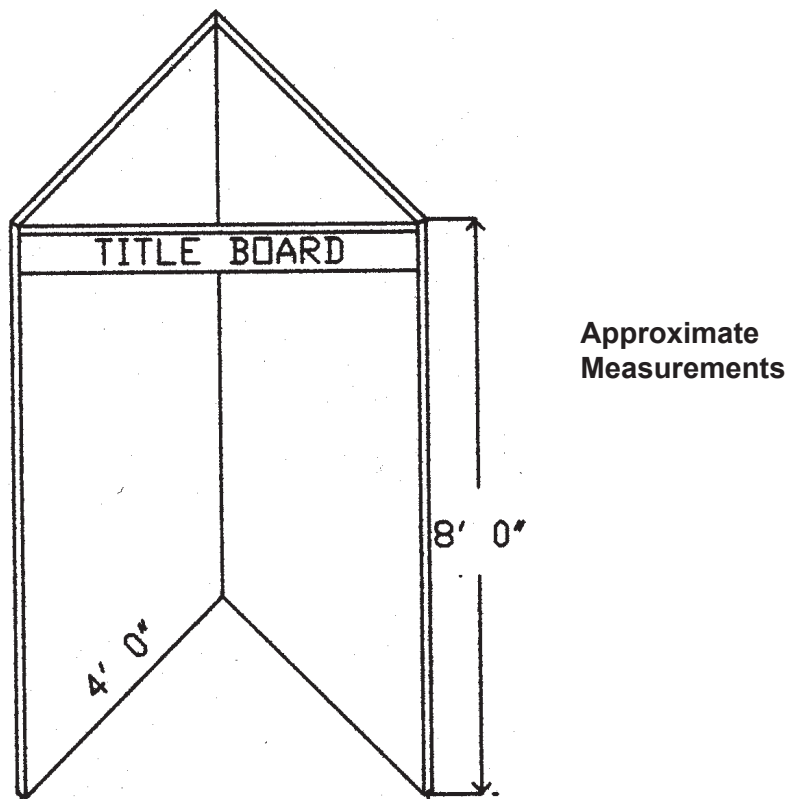

**NOTE: The 12"x5'6" title board must be displayed across the top.** Exhibits may not extend outside of the stated measurements.

There will be a 2 point deduction for not following guidelines.

The FCCLA Chapter Booth rating information: Each of the five main categories listed below receive equal weight, with a maximum of 5 points. Judges are asked to use decimal points in their scoring, e.g., 4.4, 3.8, to help avoid ties. **Note: There will be a 2 point deduction for not following guidelines.**

|  |
|--|
| <p><b>Presentation of Theme:</b><br/>                 *Used current state theme:<br/> <b>"Inspired by FCCLA"</b><br/>                 *Use of theme evident in all parts of the exhibit<br/>                 *Effective use of theme</p> |
| <p><b>Creativity of Presentation:</b><br/>                 *Attractive<br/>                 *Animated<br/>                 *Use of media and technology</p>  |
| <p><b>Neatness:</b><br/>                 *Balanced<br/>                 *Legible<br/>                 *Attractive<br/>                 *Colors Coordinate</p>  |
| <p><b>Educational Value:</b><br/>                 *Promotes FCCLA<br/>                 *Provides information to the public</p>   |

|   |
|---|
| <p><b>Relationship to State or National Programs:</b><br/>                 *Use of current state or national programs evident.</p> <p>Chapters may choose whether to spotlight one state and/or national program or to showcase more than one or all of the programs. Judges are instructed not to penalize chapters for limiting the booth to one or a few of the programs and not to award additional points for showcasing many programs.</p> <p><b>State Programs:</b><br/>                 ___ Adopt-A-Chapter<br/>                 ___ Camp Participation<br/>                 ___ Chapter Contributions<br/>                 ___ Chapter Leadership Training<br/>                 ___ Foundation<br/>                 ___ Legislative Connections<br/>                 ___ Membership<br/>                 ___ Say Yes to FCS<br/>                 ___ Scholarships<br/>                 ___ State Outreach Project</p> <p><b>National Programs:</b><br/>                 ___ Advisor Recognition<br/>                 ___ Alumni and Associates<br/>                 ___ Career Connection<br/>                 ___ FACTS<br/>                 ___ Financial Fitness<br/>                 ___ Families First<br/>                 ___ Japanese Exchange Program<br/>                 ___ Leadership Service in Action<br/>                 ___ Power of One<br/>                 ___ STAR Events<br/>                 ___ Step 1<br/>                 ___ STOP the Violence<br/>                 ___ Student Body</p> |
|---|

Don't miss the FCCLA Leadership Rally at the Georgia National Fair!  
 Wednesday, October 11, 2017, in Reaves Arena.  
 All affiliated members and chapters are invited to participate.

Registration begins - 8:30 A.M.  
 Leadership Rally begins - 10:30 A.M.

See [www.gafccla.com](http://www.gafccla.com)  
 for complete details!

2017 Sponsor for the  
 FCCLA Bonus Awards



PUBLIX SUPER MARKETS  
**CHARITIES**

**FCCLA BROCHURE**

Coordinator

678-735-0091 • gafccla@gmail.com

**THIS IS A CHAPTER EVENT AND SHOULD BE ENTERED IN THE CLUB NAME  
(EXAMPLE: Smith High School FCCLA).**

Enter online at [www.GeorgiaNationalFair.com](http://www.GeorgiaNationalFair.com)(http://www.georgianationalfair.com/youth-educational-exhibits/) by **September 20, 2017.**

**BROCHURES MUST BE POSTMARKED BY SEPTEMBER 20. ONLY HARD COPIES WILL BE ACCEPTED.** School Name, Category and Level must be on a separate sheet of paper. Only one entry per school total. **Mail brochures to the Georgia FCCLA office at 283 Swanson Drive, Suite 204, Lawrenceville, GA 30043** - must be postmarked by September 20. No late entries will be accepted for any reason.

**DIVISION 20203 FCCLA BROCHURE MIDDLE SCHOOL**  
**DIVISION 20204 FCCLA BROCHURE HIGH SCHOOL (GRADES 9-12)**

**CLASS**

- 01 Male Recruitment**
- 02 One National Program or State Program**
- 03 Alumni & Associates Recruitment**
- 04 General FCCLA Information (to provide to business and industry partners)**

|            |            |            |            |                              |
|------------|------------|------------|------------|------------------------------|
| <u>1st</u> | <u>2nd</u> | <u>3rd</u> | <u>4th</u> | Rosette to Division Champion |
| \$100      | \$75       | \$50       | \$25       |                              |

**A copy of the online registration confirmation will be required to check-in for competition.**

**CONTEST RULES:**

- 1. ALL EXHIBITORS ARE REQUIRED TO READ AND ABIDE BY THE GEORGIA NATIONAL FAIR GENERAL RULES AND REGULATIONS. PLEASE NOTE: IT IS YOUR RESPONSIBILITY TO READ AND UNDERSTAND THE RULES. IF YOU HAVE QUESTIONS, YOU MAY CERTAINLY EMAIL US AT CONTESTS@GNFA.COM. PLEASE HELP US PREVENT ENTRY DISQUALIFICATIONS.**
2. Entries are limited to one entry total per chapter (i.e. one entry in Membership Brochures, OR one in Informational Brochures for Adult Audience, etc.)
3. Entries must be the original work of the local chapter. Copy-ready brochures provided by the state or national offices are not acceptable. Official logos may be used, however.
4. Entries must be printed on 8 1/2 x 11 inch paper. They may be trifold brochures or they may be duofold (booklet type) brochures. Each brochure is limited to ONE sheet of paper. No multipage brochures will be accepted.
5. Brochures may be color or black and white. Preprinted brochures are acceptable as are brochures on colored paper.
6. Brochures will be judged on:
  - a. Effectiveness of the message
  - b. Incorporation of the current National Theme "Inspired by FCCLA"
  - c. Page layout, principles used in design, clip art selection and placement, font selection and usage
  - d. Creativity of the Presentation
  - e. General Appearance (Neatness, legibility, balance)
  - f. Accuracy and Appeal of information provided
7. Entrants agree to permit the use of their brochure to promote FCCLA in Georgia should GA FCCLA elect to use the brochure entry for that purpose.
8. Winners will be announced during the Rally on Wednesday, October 11.

# EIGHTH ANNUAL FCCLA CHILI COOK-OFF COMPETITION

Coordinator  
678-735-0091 • gafccla@gmail.com

**THIS IS AN INDIVIDUAL EVENT AND SHOULD BE ENTERED IN THE INDIVIDUAL'S NAME (EXAMPLE: Bobby Smith).**

Enter online at [www.GeorgiaNationalFair.com](http://www.GeorgiaNationalFair.com)  
**(<http://www.georgianationalfair.com/youth-educational-exhibits/>) by September 20, 2017.**

**WHEN:** Tuesday, October 10

## **DIVISION 20303 FCCLA CHILI COOK-OFF MIDDLE SCHOOL**

**CHECK-IN AND SETUP:** 1:00 p.m.; *Contest begins:* 1:30 p.m.

**WHERE:** Miller-Murphy-Howard Building Flower Show Area (North end of building)

## **DIVISION 20304 FCCLA CHILI COOK-OFF HIGH SCHOOL (GRADES 9-12)**

**CHECK-IN AND SETUP:** 3:00 p.m.; *Contest begins:* 3:30 p.m.

**WHERE:** Miller-Murphy-Howard Building Flower Show Area (North end of building)

### **CLASS**

#### **01 FCCLA Chili Cook-off Competition**

| <u>1st</u> | <u>2nd</u> | <u>3rd</u> | <u>4th</u> |
|------------|------------|------------|------------|
| \$100      | \$75       | \$50       | \$25       |

**A copy of the online registration confirmation will be required to check-in for competition.**

### **CONTEST RULES:**

1. **ALL EXHIBITORS ARE REQUIRED TO READ AND ABIDE BY THE GEORGIA NATIONAL FAIR GENERAL RULES AND REGULATIONS. PLEASE NOTE: IT IS YOUR RESPONSIBILITY TO READ AND UNDERSTAND THE RULES. IF YOU HAVE QUESTIONS, YOU MAY CERTAINLY EMAIL US AT CONTESTS@GNFA.COM. PLEASE HELP US PREVENT ENTRY DISQUALIFICATIONS.**
2. This Chili Cook-Off Competition will be an individual event. Only one entry per school will be allowed.
3. The competition will be limited to 20 participants in each Section and, if need be, a lottery drawing will decide the 20 competitors.
4. Each participant must be an affiliated FCCLA member.
5. Each participant must supply their own Chili ingredients and cooking equipment (single gas burner).
6. All preparation of Chili must be done on site, and from scratch – using raw meats and regular spices – no Chili mixes.
7. Each participant will be judged on the following criteria:
  - Clothing & Appearance
  - Safety & Sanitation
  - Food Handling & Preparation Temperatures
  - Equipment & Tools
  - Presentation & Appearance
  - Taste
8. Time guidelines and further details are listed on the following page.



**FOOD REQUIREMENTS:**

1. No restriction is placed on item usage. All ingredients used in the recipe should be from approved sources and maintained in accordance with approved Food Safety guidelines.
2. No pre-prepared foods are allowed – with the exception of canned tomatoes and canned beans only.
3. No pre-prepared sauce mixes or pre-mixed powders.
4. Competitors should maximize the use of fresh ingredients in the recipe.
5. No pre-cut items are allowed. All production must be on-site.
6. Each participant must bring 3 printed copies of recipe to be used in a protective sheet (2 for FCCLA and 1 for GNF use).

**TEAM COMPOSITION:**

Individual; one person per team, will represent each school, supported by a teacher to help with moving equipment. The competitor will be responsible for all set-ups, production and presentation of food to judges and clean up.

**CHILI COMPETITION WILL CONSIST OF ONE PHASE:**

1. Teams will be given 15 minutes to set up once all teams have checked in.
2. Teams will have staggered start times, dependent on the number of teams participating.
3. 1 hour for preparation and cooking.
4. 2 identical, no larger than 4” round bowls for judges; one for taste and one for show.  
NO PLATES OR OTHER ACCESSORIES MAY BE BROUGHT TO THE JUDGES/SHOW TABLE.
5. Please bring a tray to deliver the bowls to the judges.
6. 5 Points will be deducted for bowls that are larger than 4” in diameter.
7. When time is called, 2 identical bowls of Chili should be taken to the judges.

**EQUIPMENT:**

1. Teams must bring in all equipment and food that is needed to execute the Chili including a one burner butane gas burner (camping style).
2. Teams should only expect the organizer to provide a 8 foot by 2 foot table to work from, ice and potable water.
3. There is no power available for blenders, etc.

**DRESS CODE:**

1. Jeans and white T-shirt (or FCCLA T-shirt)
2. Closed-toe Shoes
3. Apron, gloves, protective head gear (hat, hair net, etc.)

**JUDGES WILL LOOK AT THE FOLLOWING:**

1. Sanitation; cold food cold and hot food hot.
2. Use of sanitation techniques for cleaning, food storage and potential cross contamination.
3. Use of tasting spoons by competitor.
4. Workspace and Time management.
5. Realistic use of ingredients, equipment and work environment.
6. **Taste:** Complimenting use of spices, tenderness of protein, appropriate use of spice heat and developed full flavor.
7. **Texture:** Protein is tender, vegetable not mushy or raw, sauce not too thin or too thick and knife cuts uniform and appropriate to overall texture and ease of eating.
8. **Color:** Should be bright, fresh and appealing. Not dull or faded.
9. **Seasoning:** Use of salt and pepper to compliment and balance use of spices. No excessively hot peppers to be used.

**CLEAN UP:**

Students are also judged on final clean up.

**ADVISERS/TEAM MANAGERS:**

Once the competition begins, teachers/parents etc. are unable to counsel students, and if they are found to be coaching students, the teacher/parent etc. will be asked to leave the viewing area, and/or viewing area will be cleared.

# FOURTH ANNUAL FCCLA GEORGIA PEANUT RECIPE CONTEST

Coordinator  
678-735-0091 • gafccla@gmail.com

**THIS IS AN INDIVIDUAL EVENT AND SHOULD BE ENTERED IN THE INDIVIDUAL'S NAME (EXAMPLE: Bobby Smith).**

Sponsored by:



&



Enter online at [www.GeorgiaNationalFair.com](http://www.GeorgiaNationalFair.com)

**(<http://www.georgianationalfair.com/youth-educational-exhibits/>) by September 20, 2017.**

**WHEN:** Wednesday, October 11

**CHECK-IN AND SETUP:** 9:45-10:15 a.m.; *Judging begins:* 10:30 a.m.

**WHERE:** Miller-Murphy-Howard Building Culinary Area (East side of building)

## DIVISION 20401 - FCCLA GEORGIA PEANUT RECIPE CONTEST

### CLASS

- 01 FCCLA GEORGIA PEANUT MIDDLE SCHOOL
- 02 FCCLA GEORGIA PEANUT JUNIOR (GRADES 9-10)
- 03 FCCLA GEORGIA PEANUT SENIOR (GRADES 11-12)

|            |            |            |            |
|------------|------------|------------|------------|
| <u>1st</u> | <u>2nd</u> | <u>3rd</u> | <u>4th</u> |
| \$100      | \$75       | \$50       | \$25       |

**A copy of the online registration confirmation will be required to check-in for competition.**

### CONTEST RULES:

1. **ALL EXHIBITORS ARE REQUIRED TO READ AND ABIDE BY THE GEORGIA NATIONAL FAIR GENERAL RULES AND REGULATIONS. PLEASE NOTE: IT IS YOUR RESPONSIBILITY TO READ AND UNDERSTAND THE RULES. IF YOU HAVE QUESTIONS, YOU MAY CERTAINLY EMAIL US AT CONTESTS@GNFA.COM. PLEASE HELP US PREVENT ENTRY DISQUALIFICATIONS.**
2. Only one entry per school per division will be allowed.
3. Competition will be limited to 30 participants and, if need be, a lottery drawing will decide the 30 competitors.
4. Each participant must be an affiliated FCCLA member.
5. Each participant will CREATE an original energy bar using raw or cooked peanuts.
6. Each participant will bring at least 3 servings of the prepared recipe to the Miller-Murphy-Howard building.
7. Each serving will need to be placed on a separate, identical, disposable plate, no larger than 6" in diameter.
8. All entries should be presented using proper sanitation techniques; for example, plastic wrap covering the dish.
9. Each participant will submit 3 identical copies of the recipe (2 for FCCLA and 1 for GNF use), each on a 4x6 index card with the participant's name and school clearly labeled. No recipes will be returned.
10. Entries will be judged on sanitation; presentation and appearance; recipe and ingredient compatibility; flavor, taste, texture, and doneness; and originality.
11. Winners will be announced when judging is complete, or at approximately 1:30 p.m.
12. This event is sponsored by the Georgia Peanut Commission and Georgia FCCLA. Premium checks will be mailed from the Georgia FCCLA office.

# **EIGHTH ANNUAL FCCLA** **CULINARY COMPETITION**

Coordinator

678-735-0091 • gafccla@gmail.com

**THIS IS AN INDIVIDUAL EVENT AND SHOULD BE ENTERED IN THE INDIVIDUAL'S NAME (EXAMPLE: Bobby Smith).**

Enter online at [www.GeorgiaNationalFair.com](http://www.GeorgiaNationalFair.com)

**(<http://www.georgianationalfair.com/youth-educational-exhibits/>) by September 20, 2017.**

**WHEN:** Wednesday, October 11

**CHECK-IN AND SETUP:** 1:15 p.m.; *Contest begins:* 1:30 p.m

**WHERE:** Miller-Murphy-Howard Building Flower Show Area (North end of building).

## **DIVISION 20501 - FCCLA CULINARY COMPETITION**

### **CLASS**

#### **01 FCCLA Culinary Competition**

|            |            |            |            |
|------------|------------|------------|------------|
| <u>1st</u> | <u>2nd</u> | <u>3rd</u> | <u>4th</u> |
| \$100      | \$75       | \$50       | \$25       |

**A copy of the online registration confirmation will be required to check-in for competition.**

#### **CONTEST RULES:**

1. **ALL EXHIBITORS ARE REQUIRED TO READ AND ABIDE BY THE GEORGIA NATIONAL FAIR GENERAL RULES AND REGULATIONS. PLEASE NOTE: IT IS YOUR RESPONSIBILITY TO READ AND UNDERSTAND THE RULES. IF YOU HAVE QUESTIONS, YOU MAY CERTAINLY EMAIL US AT CONTESTS@GNFA.COM. PLEASE HELP US PREVENT ENTRY DISQUALIFICATIONS.**
2. This Culinary Competition will be an individual event. Only one entry per school will be allowed.
3. The competition will be limited to 10 participants and, if need be, a lottery drawing will decide the 10 competitors.
4. Each participant must be an affiliated FCCLA member.
5. Each participant will be judged and given 30 minutes on the following knife skills:
  - 2 oz. Julienne Carrot
  - 2 oz. Onion Dice
  - 1 Whole Tomato Concasse
  - 1 oz. Brunoise Carrot
6. Each participant will be given one hour to prepare 2 identical "Hot Plated Meals", each plate consisting of:
  - 1 Chicken Breast (FCCLA provides)
  - 1 Appropriate Starch
  - 1 Vegetable
7. Each participant will bring own carrot, onion, and tomato to be used in the knife skills demonstration, in addition to their starch and vegetable to be used in their hot plate. Participants may use their knife cuts after they have been judged in their entrée preparation.
  - 2 identical plates for plating, no larger than 10" in diameter.
  - 2 copies of recipe in sheet protectors
8. Each participant will be given ONE 8 foot table to work with, speed racks are acceptable to bring (preferably the short ones) –and will be checked to verify no prep work has been done previously.
9. Once the competition begins, teachers/parents etc. are unable to counsel students, and if they are found to be coaching students, the teacher/parent etc. will be asked to leave the viewing area, and/or viewing area will be cleared.

Additions to Culinary Competition guidelines:

**FOOD REQUIREMENTS:**

1. No restriction is placed on food ingredients; students should bring all ingredients with them and held under correct sanitation food safety temperature guidelines
2. No pre-prepared foods are allowed, with the exception of canned items
3. No pre-prepared sauce mixes or pre-mixed powders are allowed
4. All potentially hazardous foods should be kept chilled

**EQUIPMENT REVIEW:**

1. Students must bring in all equipment and food that is needed (except the chicken breast), including up to 2 butane gas burners
2. There will be no power available for blenders, etc.

**DRESS CODE:**

1. Closed-toe, non-skid shoes appropriate for kitchen
2. Appropriate chef attire (including chef jacket, taped so school names are not visible)

**JUDGES WILL LOOK AT THE FOLLOWING:**

1. Sanitation: cold food cold and hot food hot
2. Use of sanitation techniques for cleaning, food storage and potential cross contamination
3. Use of tasting spoons by competitor
4. Workspace and time management
5. Realistic use of ingredients, equipment and work environment
6. Station clean-up
7. Taste
8. Texture
9. Color
10. Seasoning

**COMPETITION REVIEW:**

- 15 minute check-in
- 30 minutes on knife skills
- 60 minutes to prepare 2 identical "hot plated meals"

**CULINARY COMPETITION SUPPLY LIST:**

- Carrot for knife skills
- Onion for knife skills
- Tomato for knife skills
- Short speed rack (optional)
- All other ingredients in meal (including 1 appropriate starch and 1 vegetable)
- 2 identical plates for plating
- 2 copies of recipe in sheet protectors (includes name of competitor)
- 1-2 butane gas burners

**FCCLA KNOWLEDGE BOWL**

678-735-0091 • gafccla@gmail.com

**THIS IS A CHAPTER EVENT AND SHOULD BE ENTERED IN THE CLUB NAME  
(EXAMPLE: Smith High School FCCLA).**

Enter online at [www.GeorgiaNationalFair.com](http://www.GeorgiaNationalFair.com)  
(<http://www.georgianationalfair.com/youth-educational-exhibits/>) **by September 20, 2017.**

**Qualification Match**

*Qualification test online only.*

*All teams will complete an online test to narrow the field to the top teams. Please visit [www.gafccla.com](http://www.gafccla.com) for more information.*

**Final Rounds**

**WHEN:** Wednesday, October 11

**CHECK-IN:** 2:00 P.M.

**WHERE:** Miller-Murphy-Howard Bldg.

**DIVISION 20601 FCCLA KNOWLEDGE BOWL****CLASS**

**01 - Culinary & FCCLA Knowledge Bowl**

**02 - FACS & FCCLA Knowledge Bowl - High School (GRADES 9-12)**

**03 - FACS & FCCLA Knowledge Bowl - Middle School**

**Winning Chapters:**

|           |       |  |
|-----------|-------|--|
| 1st place | \$500 | <b>Individual team members will receive rosettes</b> |
| 2nd place | \$250 |  |
| 3rd place | \$150 |  |
| 4th place | \$100 |  |

**A copy of the online registration confirmation will be required to check-in for competition.**

**CONTEST RULES:**

1. **ALL EXHIBITORS ARE REQUIRED TO READ AND ABIDE BY THE GEORGIA NATIONAL FAIR GENERAL RULES AND REGULATIONS. PLEASE NOTE: IT IS YOUR RESPONSIBILITY TO READ AND UNDERSTAND THE RULES. IF YOU HAVE QUESTIONS, YOU MAY CERTAINLY EMAIL US AT CONTESTS@GNFA.COM. PLEASE HELP US PREVENT ENTRY DISQUALIFICATIONS.**

2. Every affiliated FCCLA Chapter is invited to bring one Culinary OR one FACS four-person team for one of the sections above. **No school may enter more than one team in the Knowledge Bowl competition unless they have more than one chapter charter. Please see box at the bottom of page 1 for additional instructions.**

3. Study materials and background information are available through the FCCLA State Office and are posted on the Georgia FCCLA website at [www.gafccla.com](http://www.gafccla.com). Questions for all classes will be comprised of 50% FCCLA and 50% content area information.

4. Each round will consist of twenty-five questions. This will be a single elimination tournament. The top sixteen highest scoring teams from the online testing will compete in the Final Rounds on Wednesday. The sixteen teams will be eliminated to four teams. The two winners from this bracket will compete for first and second place. The two losing teams from this bracket will compete in a consolation round for third and fourth place honors.

## KNOWLEDGE BOWL 2017 Competition Guidelines

There are three areas of the FCCLA Knowledge Bowl. Each chapter is invited to bring one Culinary OR one FACS or one Middle School team. A chapter cannot have more than one team in the Knowledge Bowl competition.

- The Middle School/FCCLA Knowledge Bowl is a three level, team competition that challenges students' knowledge of all aspects of Middle School questions and FCCLA.
- The Family and Consumer Sciences/FCCLA Knowledge Bowl is a three level, team competition that challenges students' knowledge of all aspects of Family and Consumer Sciences and FCCLA. All questions throughout the Family and Consumer Sciences/FCCLA Knowledge Bowl will fall under one of the following five categories: Nutrition and Food Science, Textiles, Housing and Interiors, Child and Family Development, Consumer Economics or FCCLA Knowledge
- The Culinary/FCCLA Knowledge Bowl is a three level, team competition that challenges students' knowledge of all aspects of Culinary Arts and FCCLA. All questions throughout the Culinary/FCCLA Knowledge Bowl will fall under one of the following two categories: Culinary Arts Knowledge, FCCLA Knowledge

### LEVEL 1 – Online Testing Qualification

Registration for Level 1 takes place through the Georgia National Fair registration AND Georgia FCCLA online registration process. Registration will end September 20. Online testing will take place the week of September 25 through September 29. Top teams advancing to Level 2 will be sent a confirmation of their Level 2 participation via email by October 4th.

All teams should be comprised of four FCCLA members (affiliated at both the state and national level by October 1) from the same chapter. Team members may be mixed in grade level and FACS course background. Each qualifying team may select one alternate team member from the students in their chapter. All competitors must be registered for Fall Rally at which their competition takes place. Teams with less than four members are ineligible to compete.

All teams that registered will complete this LEVEL 1 round. Teams will be comprised of four FCCLA members from a single school or chapter. Each team member will take the online test which contains ONLY content questions, no FCCLA knowledge questions will be used.

Each school must register a proctor in the Georgia FCCLA online registration system by September 20. Proctors will be emailed the password and log in information prior to testing. Proctors cannot be the FCCLA Advisor or other FACS teachers.

One hour will be given for individuals to complete the 50 question test (multiple choice and true/false questions). ALL 4 team members will need to take the test independently, but at the same time. They will NOT be the exact same questions from the Study Guide. Questions may vary. There will not be any FCCLA questions on the Online Qualification Test.

If less than four members are present to take the test or do not take the test at the same time, the team is ineligible to compete. The teams with the top team scores will advance to the next level. Chapters will not receive the scored tests back.

### LEVEL 2 – Buzzer Round at Georgia National Fair

Single Elimination takes place at Georgia National Fair (Miller Murphy Howard Bldg) on Wednesday, October 11.

The second level will be a single elimination, head-to-head competition. Teams will be put into a bracket with the top scoring team against the lowest scoring team, and so on to meet in the middle. If an odd-number of teams are competing, byes will go to the highest scoring team(s). Competition will take place simultaneously in 2 rooms, or as space allows with a holding room. All rooms will use the same questions.

Level 2 rounds consist of two parts – Head-to-Head Individual Questions as well as Team Questions. In the Head-to-Head Individual part of the round, one content (Middle Level, FACS or Culinary) multiple choice question will be asked to each team member. In the Team Questions part of the round, all questions are open-ended. Twelve questions will be asked in content and eight FCCLA Knowledge questions. Questions will be asked in the following order:

1. 12 content (Middle Level, FACS or Culinary) questions
2. 8 FCCLA knowledge questions

Elimination round is single elimination. Winners will advance to the next bracket level. If multiple rooms are used for competition, all rooms will use the same questions.

#### Buzzer Round Rules of Play

##### Level 2

##### Head-to-Head Individual Questions Rules

Questions in the head-to-head individual part of the round are multiple choice. Each team member is assigned a number – member #1, #2, #3, #4. After the question and answer choices are read to team members #1, whichever individual buzzes in first has 10 seconds to respond. The individual cannot confer with team members. Individuals may give the full answer or the letter (a, b, or c) associated with the answer. A total of 4 questions will be asked.

If the individual who has buzzed in cannot answer in the time allowed, or gives an incorrect answer, the opposing individual team member has 10 seconds to provide an answer.

If a member buzzes in before the entire question is read, the individual must give an answer within 10 seconds. If the answer is incorrect, the moderator will re-read the question and answer choices. The opposing team member has 10 seconds to respond.

If neither individual buzzes in within 10 seconds, nor both members give incorrect answers, the moderator will give the correct answer.

Each correct answer is worth 10 points. There is no deduction for incorrect answers.

This process will continue through team member #4. Upon completion of the head-to-head individual part of the round, scores will be tabulated and announced by the scorekeeper and moderator.

##### Team Questions Rules

Questions in the team questions part of the round are open ended. The moderator will ask a question, and the first person to hit his or her button will have the opportunity to answer.

Teams may buzz in before the entire question is read. If this happens, the moderator will stop reading the question. The moderator will call on the team that buzzed in. The team member who buzzed in has 10 seconds to answer the question. The team may confer both orally and in writing until a team member buzzes in. Only the team member who buzzed in will be allowed to answer the question.

If an incorrect answer is given, the moderator will begin re-reading the question, and members from the other team may buzz in at any time.

If no one buzzes in within 10 seconds after the question has been read, or both teams give incorrect answers, the moderator will give the correct answer.

Each correct answer is worth 5 points. There is no deduction for incorrect answers.

This process will continue through all 20 open ended questions. Upon completion of the team questions part of the

round, scores will be tabulated and announced by the scorekeeper and moderator. If there is a winner, the winner will be announced. If there is a tie that must be broken, tie breaker question(s) will be read.

#### Tie Breaker Round Rules

Up to five tie-breaker questions will be asked. There is no deduction for incorrect answers. The first team that buzzes in will have 10 seconds to answer. The first team to correctly answer a tie breaker question will be announced as the winner.

#### General Rules

##### Acceptability of Answers

Only the first answer from the team member who buzzes in will be accepted. Only one team member may buzz in per question. The moderator will determine if the answer given by the competitor matches the correct answer. If there is a question about the acceptability of the answer, the moderator may consult with the room judge.

##### Appeals

Following the correct answer being given by the moderator, either by one team or the moderator, the team captain of a team which has given an answer thought to be correct and in the appropriate manner may buzz in to question the incorrectness of his/her team's answer or the procedure by which the answer was not accepted. One additional team member may assist in explaining the reason for the appeal, but the appeal must be proposed by the team captain. The judge will make the final ruling based upon the explanation. Appeals must take place before the moderator begins the next question and will not be considered at another time during or following the round. Only one appeal is permitted per team, per match. Interference from the audience will result in the appeal being dismissed.

##### Consultation

Team members may confer with one another both orally and in writing until a team member buzzes in. From the time a competitor buzzes in until the time the moderator announces whether the answer is correct or incorrect, no one on that team should speak or write notes to another. If consultation continues while a team member has buzzed in, his/her answer will not be accepted even if it is correct. Team members of the opposing team may consult while a competitor on the other team is answering the question.

##### Dress Code

Participants should follow the approved conference dress code for participation in all levels of competition.

##### Moderator/Judge/Question Error

If the moderator misspeaks or misreads a question, but catches the mistake prior to either team buzzing in, they may repeat the question correctly and the time for answering will begin again at 10 seconds.

The judge and/or moderator may see that a replacement question is used if an answer is prematurely given by the moderator, judge, or spectator or if the way a question is read is deemed unfair for either or both teams. Replacement questions will not be used if a competitor reveals the correct answer out of turn or if a competitor or spectator disagrees with the correctness of answer as determined by the moderator and judge.

##### Repeating of Questions

Individual team members may request a multiple choice question to be repeated during the Head-to-Head Individual Round. No open-ended questions will be repeated once they have been read in their entirety. If there is an issue in which the moderator feels the question should be repeated (noise interference or equipment problem) they may



repeat the question at their discretion.

#### Spectator/Participant Conduct and Sportsmanship

The buzzer round is open to spectators (students, advisors, chaperones, alumni, and other conference attendees) as space in competition rooms permits. Spectators are not allowed to enter or leave the competition room during play. Spectators are prohibited from cheering, visual signaling, audible conversations, and the use of cell phones during competition. Any spectators who disrupt the round in any way or are thought to be communicating with competitors will be asked to leave by the room judge or moderator. The room judge and moderator have the authority to control the competition atmosphere within their room. Disputes concerning their judgment should be directed to the Knowledge Bowl Coordinator or the on-site state staff person who is overseeing the competition.

Good sportsmanship is expected of all participants, advisors, chapter members, and other spectators. Poor sportsmanship on the part of any team member or their supporters may result in disqualification. Any use of extremely negative behavior (such as the use of profanity or yelling) will result in immediate disqualification of the team.

#### Substitution

Substitution of team members between Level 1 and Buzzer Round will be allowed. Substituted competitors must be affiliated members of the same FCCLA chapter to qualify.

#### Team Captain

Each team should select one of its members to serve as the team captain. This member will be responsible for picking up team materials.

#### Team Holding Room

All teams in the buzzer round are required to remain in a holding room throughout the competition time period. Teams may utilize printed study material. The use of cell phones, or other electronic devices which may record, publish, or receive information are prohibited.

#### Unanswered Questions

If a question is not answered by either team, no points will be awarded or lost and no replacement question will be given. The moderator will give the correct answer and move on to the next question.

#### Writing Instruments

Paper and pencils for each competitor will be provided by FCCLA. Competitors will not be allowed to bring any writing tools or paper into the competition room.

Georgia FCCLA Online Qualification Test  
September 25-29, 2017

#### Preparing for Online Testing

1. Ensure your students are registered in the Georgia National Fair AND Georgia FCCLA online system by midnight on SEPTEMBER 20.
2. Secure AND register (by September 20) a non FCCLA/FACS related testing proctor. This person will receive the secure password from Georgia FCCLA to log your students into the system when they report to test. Suggestions include librarians, counselors, administrators, IT staff, etc.
3. Secure a computer testing site with internet access that will accommodate the number of students you will be testing during the testing window.

4. Make sure that your school computers can access the testing site: <https://www.answerwrite.com/fccla/ga>. As of now, the online testing link is not available. The network administrators need to know this ahead of time so they can add it to the list of trusted sites.
5. Confirm the testing times with each of your students and ensure they know where they will be testing. Make sure students taking the same test are all testing at the SAME TIME.
6. Proctors will be emailed login instructions. Without this documentation in hand, they will not be able to log your students in for competition. Please verify they get a copy of this.
7. If in doubt about anything, call the state office at (678) 735-0091 OR email [gafccla@gmail.com](mailto:gafccla@gmail.com) so we can help you have a successful testing week. PLEASE GIVE THIS PHONE NUMBER TO YOUR PROCTOR!

#### Registration

1. Registration for this event happens in TWO places: Georgia National Fair and Georgia FCCLA. The names must match in both systems. Please visit the Fall Rally event page on the Georgia FCCLA website for registration instructions for the Georgia FCCLA registration system.

#### Things to Know

- Only teams registering with BOTH the Georgia National Fair AND Georgia FCCLA will be eligible to test.
  - All tests will be available at any time during the testing window.
  - A proctor (non FCCLA/FACS) must be available to access the online system.
  - Timing of the test session will begin when the test/questions are presented, not when the first question is answered.
  - Responses will be automatically submitted when the time expires. The time limit will be 1 hour for each test.
- Tests will consist of 50 multiple choice questions.
- The entire test is accessible throughout the test session.
  - Please review the use of scroll bars with competitors prior to testing and remind them not to close the testing window.
  - Closing the test window terminates the test without scoring and disqualifies the competitor in this event.

#### After the Test

- Although the test will be scored upon submission, the score will not be available to the competitor or the advisor.